

THETFORD

BUILD IN APPLIANCE

FOR USE WITH PROPANE GAS

MODELS:

- S~OH72000 MK3 CAPRICE (ALL GAS)
- S~HG72000 MK3 MINIGRILL (ALL GAS)
- S~OH73000 MK3 CAPRICE (DUAL FUEL)
- S~HG73000 MK3 MINIGRILL (DUAL FUEL)

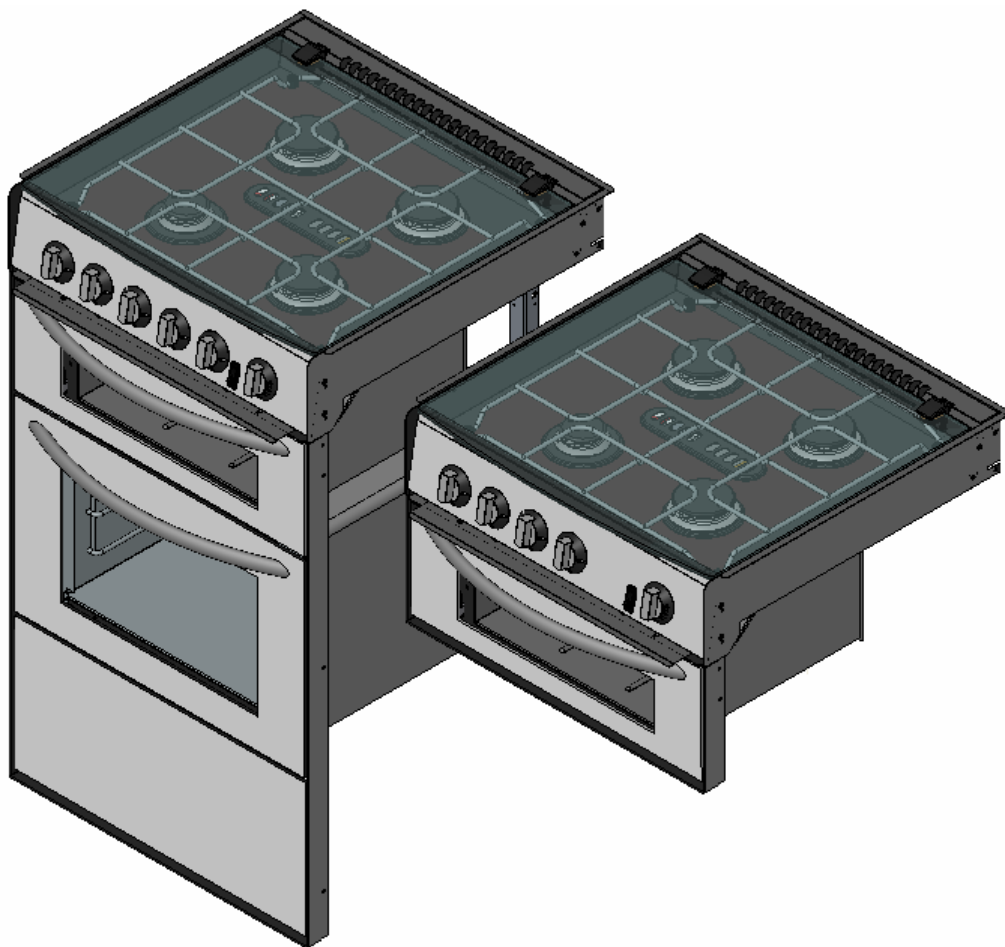

USER AND INSTALLATION INSTRUCTIONS

PLEASE READ THOROUGHLY AND KEEP FOR FUTURE REFERENCE

FOR USE IN AUSTRALIA

THETFORD AUSTRALIA PTY LTD
41 LARA WAY CAMPBELLFIELD VIC
TEL: 03 9358 0700 FAX: 03 9357 7060

INSTALLATION DETAILS (See next page for Trim types)

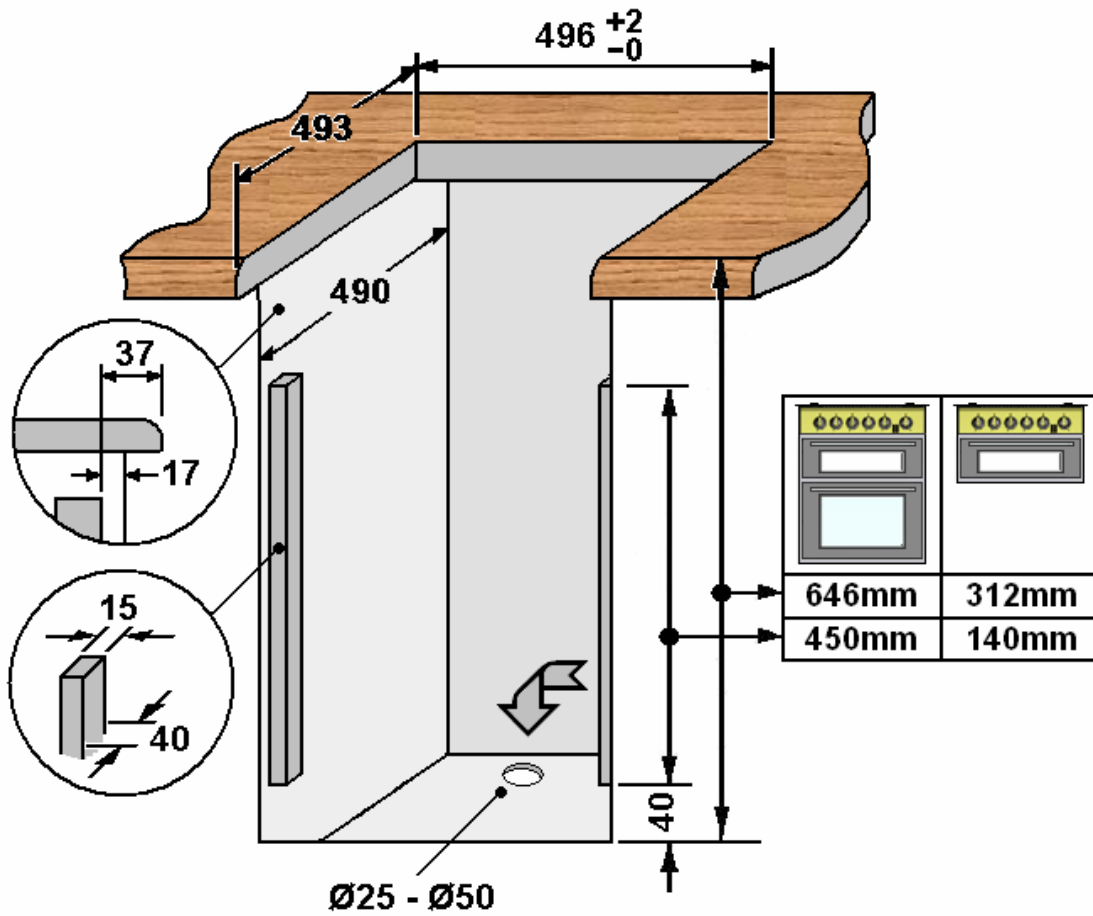

MINIMUM DISTANCE TO COMBUSTIBLE MATERIAL

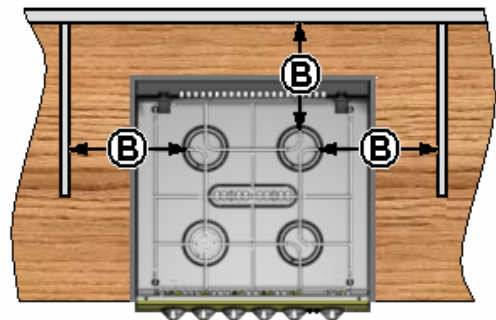
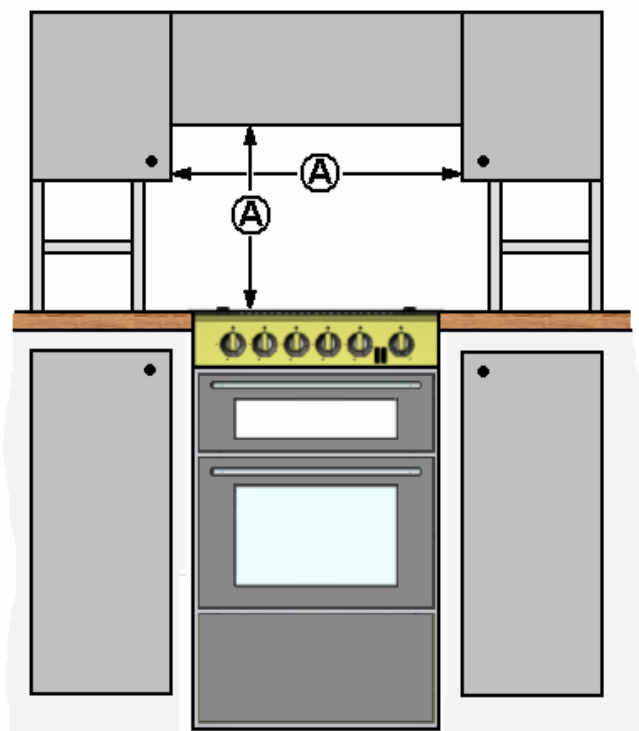

Ⓐ = 500mm

Ⓑ = 200mm

EUROPEAN TRIMS

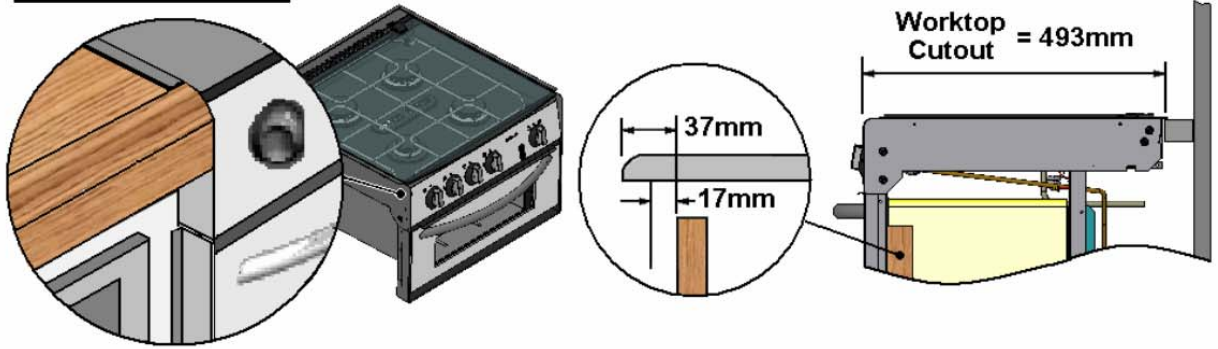

AUSTRALIAN TRIMS

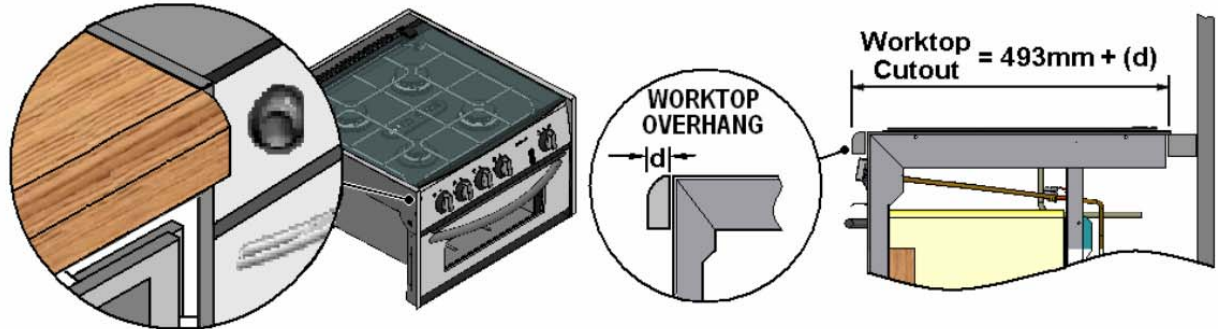

WIRING DIAGRAM

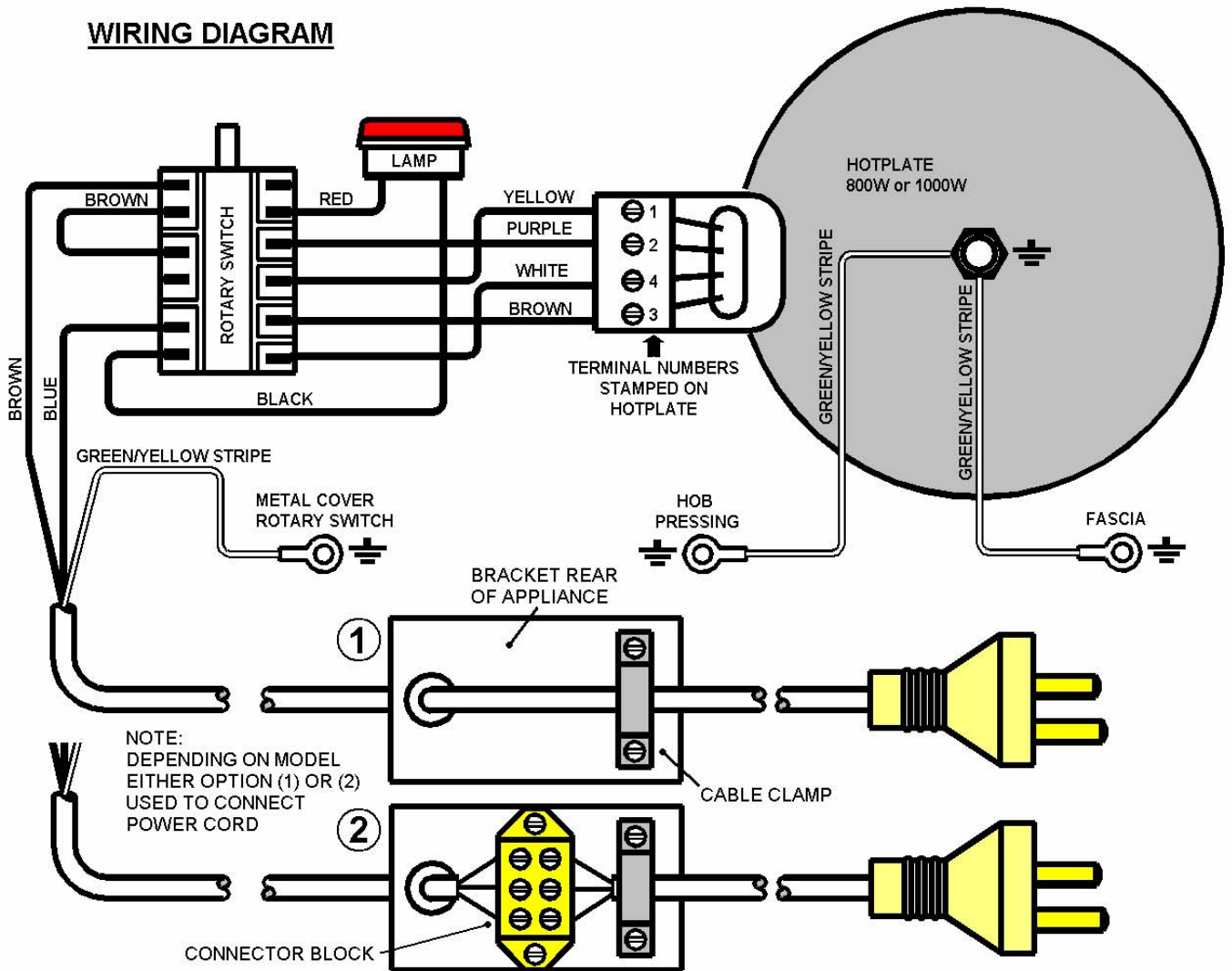

MODEL	Mk3 CAPRICE	MODEL	Mk3 CAPRICE	MODEL	Mk3 MINIGRILL	MODEL	Mk3 MINIGRILL
TYPE	DUAL FUEL	TYPE	ALL GAS	TYPE	DUAL FUEL	TYPE	ALL GAS
CODE	S~OH73000Z	CODE	S~OH72000Z	CODE	S~HG73000Z	CODE	S~HG72000Z
	H (mm) 644 W (mm) 513 D (mm) 500 V³= 36Ltrs		H (mm) 644 W (mm) 513 D (mm) 500 V³= 36Ltrs		H (mm) 311 W (mm) 513 D (mm) 500		H (mm) 311 W (mm) 513 D (mm) 500
	MJ 1 x 3.8 2 x 5.9 1 x 800W 240V~50Hz		MJ 1 x 3.8 3 x 5.9		MJ 1 x 3.8 2 x 5.9 1 x 800W 240V~50Hz		MJ 1 x 3.8 3 x 5.9
	26.6MJ/hr (Gas) 800W (Electric)		32.5MJ/hr (Gas)		20.9MJ/hr (Gas) 800W (Electric)		26.8MJ/hr (Gas)
	12V dc		12V dc		12V dc		12V dc
	26.8Kg		25.2Kg		16.2Kg		14.5Kg

Note: Dual Fuel appliances available with alternative 1000W Electric Hotplate



- This appliance is suitable for use with liquefied petroleum gas (LPG) and should not be used on any other gas.
- Use only the gas pressures specified.
- This appliance MUST be earthed.
- If the power cord is damaged, it MUST be replaced by the manufacturer, its service agent or a similarly qualified person in order to avoid a hazard.

INTRODUCTION

This appliance must be installed in accordance with the manufacturers installation instructions, local gas fitting regulations, municipal building codes, AG5601 and any other relevant statutory regulations. Particular attention shall be given to the requirements regarding ventilation. Read the instructions before installing or using the appliance

The appliance is designed for either high or low level installations. Failure to install the appliance correctly could invalidate any warranty or liability claims and lead to prosecution. Please refer to the methods of installation within this handbook.

Our policy is one of continuous development and improvement. Specifications and illustrations may change subsequent to publication.

Data label.

The data label is located on the right hand side front of the oven compartment, behind the oven door. A duplicate data label is supplied to adhere to an accessible area next to the appliance. Ensure that the gas supply is Propane. This appliance is designed for use with Propane gas and should not be converted for use with any other gas.

Provision Of Ventilation

The use of a gas cooking appliance results in the production of heat and moisture in a room in which it is installed. Ensure that the kitchen is well ventilated, keep natural ventilation holes open or install a mechanical ventilation device (mechanical extractor hood).

Prolonged intensive use of the appliance may call for additional ventilation, for example opening a window, or more effective ventilation, for example increasing the level of mechanical ventilation where present. The room containing the appliance should have an air supply in accordance with local, national and European standards.

Position

This appliance must be positioned free from draughts, which may affect the combustion and in a manner that will prevent the accumulation of unburnt gas. When in use ensure that air vents are not inadvertently blocked or shut off.



Where this appliance is installed in Marine Craft or in Caravans, it shall NOT be used as a space heater.



Before using the appliance for the first time, remove all accessories and packing in the grill and oven, including any surface protection film, ie plastic coating. Clean all interior surfaces with hot soapy water to remove any residual protective covering of oil and rinse carefully.

OPERATION



- **The appliance is not intended for use by young children or infirm persons, without supervision**
- **Young children should be supervised to ensure they do not play with the appliance.**
- **Glass lids may shatter when heated. Turn off all burners before shutting the lid**
- **Spillage on the surface of the lid should be removed before opening the lid.**

Burner operation

The burners on this appliance have fixed aeration and no adjustment is required. The burners should flame as follows:-

Propane - The flames should burn quietly with a blue/green colour with no sign of yellow tips.



- **Although each burner will support pans from 10 to 22cm, care should be taken not to overload the appliance as reduced performance may result.**
- **When using small pans the flames should not spread beyond the base of the pan as this will reduce the efficiency of the burner.**
- **Avoid old or misshapen pans as these may cause instability.**
- **The lid must be opened fully prior to using the hotplate burners.**

Using the Hotplate Gas Burners

1. Ensure gas cylinder/supply is connected and turned on. In the event of a gas smell turn off at gas cylinder/mains and contact supplier.
2. Flame supervision: Each burner is controlled individually and is monitored by a thermocouple probe. In the event of the burner flames being accidentally extinguished, turn off the burner control and do not attempt to re-ignite the burner for at least one minute.
3. To light: Push in the control knob and turn to full rate – large flame (🔥). Hold a lighted match or taper to the burner and push the control knob in and hold. It is necessary to hold the knob depressed after the burner has ignited for approximately 10 - 15 seconds, to allow the thermocouple probe to reach temperature, before releasing the knob. Should the flame go out when the knob is released, the procedure should be repeated holding the knob depressed for slightly longer.
4. For models fitted with Spark Ignition the procedure is similar except that the burner can be ignited by depressing the ignition button, which is located on the fascia. If the burner has not lit within 15 seconds the control knob should be released and the burner left for at least 1 minute before a further attempt to ignite the burner.
5. For simmering, turn the knob further anti-clockwise to the low rate position.
6. To turn off: Turn the control knob until the line on the control knob is aligned with the dot on the control panel. Always make sure the control knob is in the off position when you have finished using the hotplate burners.

OPERATION



- **Glass lids may shatter when heated. Turn off the hotplate and allow it to cool before closing the glass lid.**
- **Remove all spillage from the surface of the glass lid before opening.**

Using the Electric Hotplate

Ensure the electricity is switched on.

The hotplate control is numbered from 1 to 6. To turn it on, rotate the knob either clockwise or anti-clockwise to the required position. Position 1 is the coolest setting. To turn the hotplate off, rotate the knob until the line or pointer on the knob lines up with the zero on the control panel. The hotplate is a sealed construction and transfers heat through conduction. For maximum efficiency a correctly sized pan with a flat heavy gauge base should be used. Pan size should be the same or slightly larger (up to 1" / 2.5 cm oversize).

Before using your hotplate for the first time, we recommend that you prime and then season it.

To prime the Hotplate

Switch on the hotplate for a short period, without a pan, to harden and burn off the coating. Use a medium to high setting for 3 – 5 minutes. A non toxic smoke may occur during this process. Allow it to cool, then season.

To season the Hotplate

First heat the hotplate for 30 seconds on a medium setting, then switch off. Pour a minimal amount of unsalted vegetable oil onto a clean dry cloth or paper towel, and apply a thin coat of oil to the hotplate surface. Wipe off any excess oil, then heat the hotplate on a medium setting for 1 minute. Occasional seasoning will help to maintain the Hotplate's appearance.



- **Depending on specification, your appliance may be fitted with a glass lid shut-off system, which cuts off the power to all hotplate burners (gas and electric) if the lid is closed.**
- **Ensure the glass lid is in the open and upright position before turning on the hotplate burners.**
- **Not all models are fitted with the shut-off system.**

OPERATION



- **The pan supplied with the appliance is multi functional, for use in grill or oven.**
- **The handle can be removed or inserted whilst the pan is in use.**
- **Always remove the handle when the pan is in use.**

Using the Grill

1. Ensure gas cylinder/supply is connected and turned on. In the event of a gas smell turn off at gas cylinder/mains and contact supplier.
2. To light: Open door, push in the control knob and turn to full rate – large flame (☹). Hold a lighted match or taper to the burner and push the control knob in and hold. The burner should ignite and the control knob should be held in for 10 -15 seconds before release. If the burner goes out, repeat procedure holding control knob for slightly longer.
3. For models fitted with Spark Ignition the procedure is similar except that the burner can be ignited by depressing the ignition button, which is located on the fascia. Ignition must be carried out with the door open, and if the burner has not lit within 15 seconds the control knob should be released and the grill left for at least 1 minute before a further attempt to ignite the burner.
4. Note: the grill must only be used with the door open.
5. On first use of the grill, it should be heated for about 20 minutes to eliminate any residual factory lubricants that might impart unpleasant smells to the food being cooked. A non-toxic smoke may occur when using for the first time so open any windows and turn on mechanical ventilators to help remove the smoke.
6. Although the grill does heat up quickly, it is recommended that a few minutes preheat be allowed.
7. Flame Failure Device (FFD): the grill burner is fitted with a flame sensing probe, which will automatically cut off the gas supply in the event of the flame going out. In the event of the burner flames being accidentally extinguished, turn off the burner control and do not attempt to re-ignite the burner for at least one minute.
8. It is normal for the flames on this burner to develop yellow tips as it heats up.
9. A reversible grill pan trivet enables the correct grilling height to be achieved.

Fast Toasting	trivet in high position
Grilling Sausages	trivet in high position
Grilling Steak/Bacon	trivet in high position
Grilling Chops, etc	trivet in low position
Slow Grilling	trivet removed
10. To turn off: turn the control knob until the line on the control knob is aligned with the dot on the control panel. Always make sure the control knob is in the off position when you have finished grilling.



- **The grill MUST only be used with the door open.**
- **The heat deflector below the fascia should be pulled out prior to lighting the grill.**
- **Never adjust the heat deflector position without using hand protection – ie oven gloves.**

OPERATION



- **The pan supplied with the appliance is multi functional, for use in grill or oven.**
- **The handle can be removed or inserted whilst the pan is in use.**
- **Always remove the handle when the pan is in use.**

Using the Oven

1. Ensure gas cylinder/supply is connected and turned on. In the event of a gas smell turn off at gas cylinder/mains and contact supplier.
2. To light: Open door, push in the control knob and turn to gas mark 9. Hold a lighted match or taper to the burner and push the control knob in and hold. The burner should ignite and the control knob should be held in for 10 -15 seconds before release. If the burner goes out, repeat procedure holding control knob for slightly longer.
3. For models fitted with Spark Ignition the procedure is similar except that the burner can be ignited by depressing the ignition button, which is located on the fascia. Ignition must be carried out with the door open, and if the burner has not lit within 15 seconds the control knob should be released and the oven left for at least 1 minute before a further attempt to ignite the burner.
4. Place the oven shelf in the required position and close the door. Set control knob to approximately gas mark 5 and heat the oven for about 30 minutes to eliminate any residual factory lubricants that might impart unpleasant smells to the meals being cooked. A non-toxic smoke may occur when using for the first time so open any windows and turn on mechanical ventilators to help remove the smoke.
5. Although the oven does heat up quickly, it is recommended that a 10 minutes preheat be allowed. The oven should be up to full temperature in about 15-20mins.
6. To turn off: turn the control knob until the line on the control knob is aligned with the dot on the control panel.
7. Shelf: the shelf has been designed to allow good circulation at the rear of the oven and are also fitted with a raised bar to prevent trays or dishes making contact with the back of the oven. To remove a shelf, pull forward until it stops, raise at front and remove.



- **Do not store flammable materials either in or under the appliance.**
- **Do not spray aerosols in the vicinity of this appliance while it is in operation**

Oven Temperature Control

The temperature in the oven is controlled by a thermostatic gas tap and is variable over the range 130°C to 240°C. Approximate temperatures for the settings on the control knob are shown in the table below. The temperatures indicated refer to the centre of the oven and at any particular setting the oven will be hotter at the top and cooler towards the base.

The variation between top and centre, and centre to bottom is approximately equivalent to one gas mark. Good use can be made of the temperature variation in several dishes requiring different temperatures may be cooked at the same time. In this way maximum benefit can be obtained from the gas used to heat the oven.

OPERATION

Care should be taken not to overload the oven, allow adequate spacing to ensure free circulation of heat. When roasting with aluminium foil ensure the foil does not impair circulation of heat or block anythe oven flue outlet.

Gas Mark	Temperature (Centre of Oven)			Dish
	265-275°F	130-135°C		
¼ - ½			Very cool	Meringues
1	285	140	Cool	Stewed fruit
2	300	150	Cool	Rich fruit cake, rice pudding
3	330	165	Warm	Baked custard, shortbread fingers
4	355	180	Moderate	Victoria sandwich
5	385	195	Fairly hot	Whisked sponges, ginger nuts
6	410	210	Hot	Short crust pastry
7	430	220	Hot	Bread, scones, flaky pastry
8	445	230	Very hot	Puff pastry
9	465	240	Very hot	Quick browning

Do's And Don'ts

- DO read the user instructions carefully before using the appliance for the first time.
- DO allow the oven to heat before using for the first time, in order to expel any smells before the introduction of food.
- DO clean the appliance regularly.
- DO remove spills as soon as they occur.
- DO always use oven gloves when removing food shelves and trays from the oven.
- DO check that controls are in the off position when finished.
- DO NOT allow children near the cooker when in use. Turn pan handles away from the front so that they cannot be caught accidentally.
- DO NOT allow fats or oils to build up in the oven trays or base.
- DO NOT use abrasive cleaners or powders that will scratch the surfaces of the appliance.
- DO NOT under any circumstances use the oven as a space heater.
- DO NOT put heavy objects onto open grill and oven doors.

Leaks

If a smell of gas becomes apparent, the supply should be turned off at the cylinder **IMMEDIATELY**. Extinguish naked lights including cigarettes and pipes. Do not operate electrical switches. Open all doors and windows to disperse any gas escape. Propane gas is heavier than air; any escaping gas will therefore collect at a low level. The strong unpleasant smell of gas will enable the general area of the leak to be detected. Check that the gas is not escaping from an unlighted appliance. Never check for leaks with a naked flame, leak investigation should be carried out using a leak detector spray.

Regulations and Standards

This appliance must be installed in accordance with the manufacturers installation instructions, local gas fitting regulations, municipal building codes, AG5601 and any other relevant statutory regulations. Particular attention shall be given to the requirements regarding ventilation. Read the instructions before installing or using the appliance

Failure to install the appliance correctly could invalidate any warranty or liability claims and lead to prosecution. Read the instructions before installing or using this appliance.

Ventilation

This appliance is suitable for installation into Holiday Homes, Touring Caravans and Boats. In all cases the national standards with regard to ventilation for the particular vehicle into which the appliance is to be installed must be adhered to.

The appliance **MUST** have a gas escape hole (min size Ø25mm; max Ø50mm; or shaped hole of equivalent area) in the floor, directly beneath the appliance and positioned at the rear. The hole **MUST** vent to the outside and should be baffled to prevent direct draught to the appliance.

Location of Appliance

This appliance maybe installed in a kitchen/kitchen diner but NOT in a room containing a bath or a shower. LP gas appliances must not be fitted below ground level. e.g. in a basement.



- **This appliance must be installed into an aperture, sealed off at either side in order to prevent draughts from adjoining cupboards/vents. Ensure that air vents and gas escape holes are kept clear, holes for cables and pipes must be sized to minimize air leakage between compartments.**
- **Under no circumstances should the ventilation hole exceed the maximum specified. Low level vents in adjacent compartments are permitted.**

Position

A cutout should be prepared as shown in the enclosed diagrams. The cutout **MUST** comply with the dimensions shown and include the low ventilation indicated.

A horizontal distance of 200mm must exist between the edge of the burner and combustible material unless protected by a layer of non-combustible material. Unless the appliance is fitted with a glass lid a non-combustible heat shield (splash back) must be fitted onto the rear wall directly behind the appliance.

This appliance must be positioned free from draughts, which may affect the combustion, and in a manner that will prevent the accumulation of unburnt gas. When in use ensure that air vents are not inadvertently blocked or shut off. Ensure all combustible materials such as curtains and shelves are well clear of the appliance.

The performance of this appliance meets the requirements of the Australian Standard for Domestic Cooking Appliances. We recommend the installation follows the minimum dimensions shown in this manual as any deviation could result in excessive temperature rise. If minimum dimensions must be reduced, due to design constraints, a temperature rise test of all furniture fitted around the unit **MUST** be performed. The design is deemed permissible providing the results of this test comply with all standards in force and the requirements detailed within the furniture manufacturer's material specification. Where minimum dimensions are reduced we recommend protecting with non combustible material.

INSTALLATION

Fixing

This appliance can be front or side fixed, holes are provided for either installation method.

Front Fixed Appliance	Side Fixed Appliance
1 front fix hole each side of Grill opening	1 side fix hole each side of Grill opening
1 front fix hole each side of Oven opening	1 side fix hole each side of Oven opening
2 fixing holes in each Hotplate side trim	2 fixing holes in each Hotplate side trim

Make sure the appliance is fully home in the cabinet/aperture prior to screw fixing.



When installing DO NOT lift appliance using the door handles

Connection - Gas

A ¼" BSP taper gas inlet connection is provided on the rear of the appliance. Refer to the diagrams at front of booklet for the location of the gas inlet. It is recommended that the appliance is connected by copper tubing. A rubber or hose connection must not be used. After connection the appliance must be tested for soundness.

This appliance is suitable for use on

PROPANE GAS ONLY 2.75Kpa.

It is important that the regulator should be set to the correct pressure for the type of gas being used. Excessive pressure must not be permitted.

If the flame on either the top burners or the grill should show a tendency to lift, it is possible that the line pressure is too great. Should there be excessive yellow tips (resulting in sooting) then it is possible that the line pressure is too low. In either case the burners should not be used until the line pressure has been checked out.

The burners on this appliance have fixed aeration and no adjustment is necessary.

Connection - Electrical

The appliance is supplied with a power cord and plug which must be connected to a double pole switched mains supply, with 3mm minimum contact separation at all poles.

Any excess power cord **MUST** be routed away from the appliance and not come into contact with the appliance or hang loose into a lower compartment.

When satisfied with the appliance, please instruct the user on the correct method of operation. If the appliance fails to operate correctly after all checks have been made, refer to the authorised service provider in your area.



- **This appliance must be earthed**
- **If the supply cord is damaged, it must be replaced by the manufacturer, its service agent or a similarly qualified person in order to avoid a hazard**
- **After installation the appliance MUST be tested for soundness**
- **Test ALL burners on high and low flame for flame stability.**
- **The gas supply input pressure MUST not rise or fall significantly from nominal when ALL appliances connected to the supply are operated simultaneously.**



- **Shut off gas supply at isolating valve, switch off electric supply and ensure all parts are cool before cleaning or servicing**
- **All servicing must be carried out by an approved competent person.**
- **After each service the appliance must be checked for gas soundness**
- **This appliance must not be modified or adjusted unless authorized and carried out by the manufacturer or his representative. No parts other than those supplied by the manufacturer should be used on this appliance.**
- **If the supply cord is damaged, it must only be replaced by the manufacturer or his representative in order to avoid a hazard.**

This appliance needs little maintenance other than cleaning. All parts should be cleaned using warm soapy water. Do not use abrasive cleaners, steel wool or cleansing powders. When cleaning the burner ring it is essential to ensure that the holes do not become blocked. The control knobs are a push fit and can be removed for cleaning.

Who to Contact

For service, please contact your authorised local Service Agent giving full details of the model, serial number and date of purchase.

Manufactured by: THETFORD Limited.

Unit 19 Oakham Drive, Parkwood Industrial Estate,
Rutland Road, Sheffield. S3 9QX. England.

1. Remove appliance from housing

Shut off both gas & electric supply. Lift the glass lid and remove 2 screws from either side of the hob surround trim and close the lid. Open the grill door, oven door and lower door, remove the fixing screws – note the appliance can either be front or side fixed, see under **Fixing**, page 11. Carefully slide the appliance out one third to gain access and disconnect the gas supply. Check for any possible snagging of wires or pipes. If OK, lift appliance out onto a suitable surface

2. Remove the hob surface

Shut off both gas & electric supply. Lift off the pan rest and remove the two screws securing each burner cap and spreader. Carefully remove front fascia by removing all the push on control knobs and unscrewing the 2 recessed fixing nuts. Remove the 2 standoff studs securing each burner cup. Remove the 2 screws securing the pressing to the rear box section. Grasp the hob by the angled front face, carefully lift the hob surface tilting from the front to allow rear edge to unhook from rear box section. The hob surface should be put onto a suitable surface.

3. Control replacement –Hob and Grill

Shut off both gas & electric supply. Remove the hob surface (2). Unscrew the corresponding pipe and thermocouple and remove from the control. Remove the locknut from the front of the control panel. Disengage the control from the gas rail and remove.

4. Control replacement - Oven thermostat

Shut off both gas & electric supply. Remove appliance from housing (1). Remove the hob surface (2). Open the oven door and unscrew the 2 screws holding the thermostat probe in position and push the probe back out through the hole in the rear of oven. Remove the retaining screws from on top and underneath the control and remove from the gas rail. Remove the fittings off the old control and fit on the replacement.

5. Remove the grill burner assembly

Shut off both gas & electric supply. Remove the hob surface (2). Release the locking screw on the injector holder. Unscrew the thermocouple from the control and remove the spark ignition lead from the generator. Lever off starlock washers from the grill flue, remove flue clamping screw from rear cross strut and remove flue. Remove clamp screw retaining grill assembly to roof of cavity. Slide and lift out the complete grill assembly.

6. Spark Ignition – Hob and Grill (where fitted)

Shut off both gas & electric supply. Remove the hob surface (2).

Hotplate burners - Pull off the fixing clip on the burner and remove electrode from the burner cup. Trace the electrode wire back to the generator and pull off the connector.

Grill burner - Remove the screw from the bracket of the spark ignition probe in the top of the burner. Trace the electrode wire back to the generator and pull off the connector.

7. Spark Ignition - Oven (where fitted)

Shut off both gas & electric supply. Remove appliance from housing (1). Trace the electrode wire up the back of the cooker to the generator and pull off the connector.

Unscrew the fixing screw on the spark electrode inside the oven cavity, then carefully pull the electrode from inside the oven and remove.

8. Spark Generator (where fitted)

Shut off both gas & electric supply. Remove appliance from housing (1). Unplug the generator first. Remove all electrode wires and pull off all power and earth wires. Remove the two retaining screws and lift off the generator.

9. Hotplate burner injector (No67 and No53 Aux)

Lift off the pan rest, remove the burner cap and spreader and unscrew the injector.

10. Grill burner injector (No62)

Shut off both gas & electric supply. Remove the hob surface (2). Release the locking screw on the injector holder, disengage the grill pipe from the control and remove the injector.

11. Oven burner injector (No65)

Open the oven door and unscrew the burner retaining screw, slide the burner to the left and lift out. The injector is exposed to the right hand side of the cut out. Unscrew the injector.

12. Bypass replacement – all controls

Shut off both gas & electric supply. Remove the hob surface (2). Access Bypass jet from front of control bracket, through hole adjacent to corresponding control. Unscrew completely the bypass and gently lever out from its seating.

13. Hob and grill thermocouples

Shut off both gas & electric supply. Remove the hob surface (2). Unscrew the thermocouple from the control. Unscrew the nut at the burner.

14. Oven thermocouple

Shut off both gas & electric supply. Remove appliance from housing (1). Unscrew the thermocouple from the control. Inside the oven cavity, the thermocouple is found just above the burner on the rear wall. Unscrew the locknut and pull out the thermocouple from the rear of the appliance.

15. Removing doors

Grill door/Lower door - Open the door and remove the screws on top and bottom of the grill door hinges. Carefully lower the door and remove.

Oven door (drop down) - Open the door and engage catch to hook on each hinge. Lift the door and pull out of front trim.

Oven door (side opening) - Open the door and remove the 2 screws retaining the top hinge, tilt the door slightly forwards at the top and then lift the door off the bottom hinge.